

TECHNICAL BULLETIN

WIRE MESH DECKING: Surface Coatings: Zinc vs. Painted & Powder-Coated

There are primarily three different wire coatings available today for wire decking. These coatings consist of paint, epoxy type powder-coated, and galvanized (zinc) coated. Naturally, the manufacturing costs associated with producing the various coatings are different. Similarly, the origin of the product can also have an effect on cost, therefore market prices will reflect these differences. Why then would manufacturers provide consumers with different surface coatings when not all are equal in performance? The answers are many, but like most products as the adage goes, "You get what you pay for". Determining the best coating for your application requires research. For this reason, J&L has undertaken the task and performed controlled testing on the three most-common surfaces used on wire decks, paint, epoxy type powder-coated, and galvanized (zinc) coated.

Products manufactured by J&L are made here in America where materials and processes are carefully controlled in house and monitored using our designed quality procedures and material specifications. The value of a product is generally tied to its performance and benefits. Although other manufacturers claim that painted and powder coated decking are good performers, recent controlled laboratory testing has confirmed that our galvanized product, Galva-Deck™, out performs and outlasts the others. Described below are the tests with results, and general observations made during testing:

WIRE BEND TESTING – ASTM A641/641M -09a (2014)

This test, conducted by an independent laboratory, involves bending a wire around a mandrel one times the diameter of the test sample. The test is designed to show how well a coating will adhere to the base metal for protection against the elements. It is important to understand that most paint and powder-coated materials adhere to the surface of a wire by means of a chemical bond, while zinc is metallically bonded. Typically, chemical bonds are localized between specific neighboring atoms, but metallic bonds extend over the entire molecular structure. Providing the application of zinc is done in accordance with approved practices, this makes a zinc coated material superior to one that has been painted and/or powder coated, and one that is less likely to peel or flake when sharply bent.



PAINTED
Peeling Observed at Bend
FAILED Bend Test



POWDER-COATED
Peeling Observed at Bend
FAILED Bend Test



ZINC-COATED
No Peeling Observed
PASSED Bend Test

THREE SEPARATE WIRES WERE TESTED FOR EACH COATING TYPE

Testing confirms that a zinc coating, due to the metallic bond between the zinc and base metal on galvanized wire, is more likely to adhere to the surface when bent. Painted and powder-coated decks, while they may be less costly to purchase, may not provide the value, the longevity, and life of a deck manufactured with galvanized wire.

ABRASION TESTING – (Samples Tested Under Controlled Conditions)

To help demonstrate the importance of having a protective surface that adheres well to the underlying wire, competitor decks manufactured with painted and powder-coated wire were tested alongside a galvanized deck manufactured by J&L. It was the intent of this test to help simulate a wire deck that has been subjected to warehouse service. The test conditions are described below:

A pallet was loaded with zinc ingots weighing 1,554 pounds. The pallet was then slid across the full length of the deck surface at a rate of four (4) inches per second for a total of 50 cycles. Results revealed that the base metal of the wire on both the painted and powder-coated wires were exposed leaving no protection from the elements. The zinc-coated wires comprising the J&L decking did not reveal the same type of damage. Zinc was still observed protecting the base metal.



TEST APPARATUS

(Hydraulic Cylinders, Pallet Weighted with Zinc)



TEST APPARATUS

(Pallet Weighted with Zinc, Deck Under Test)



PAINTED DECK

(Wear Visible at Wire Surface)

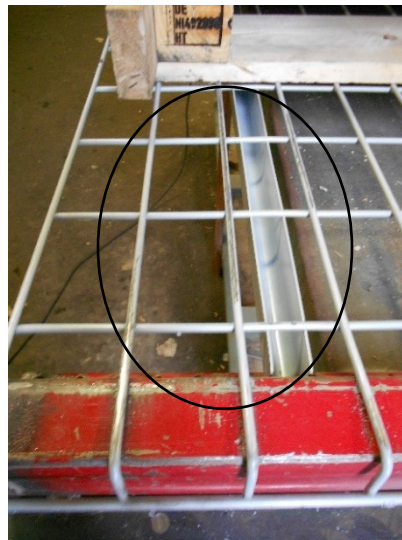

POWDER-COATED DECK

(Wear Visible at Wire Surface)

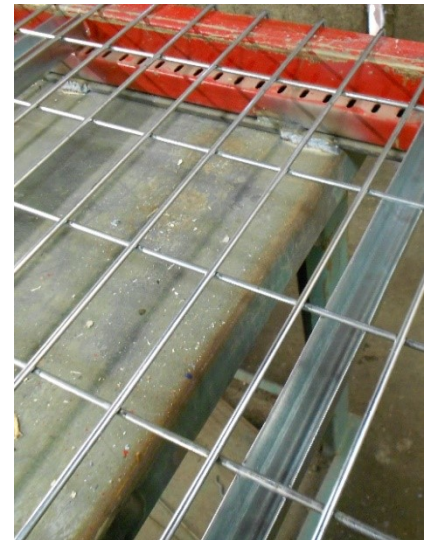

GALVANIZED DECK

(Minimal / No Wear Visible)

Both the painted and powder-coated surfaces did not hold up against the galvanized surface during testing. There was minimal wear to the wire surface on the zinc-coated wire, while both the painted and powder-coated surfaces exhibited wear and exposure of the base metal. Based on bend and wear testing, cleanliness may also be an issue with paint and powder-coated surfaces by compromising inventory. These surfaces, prone to wear and peel (flake), will settle on and into the boxes below and the warehouse floor. Protection of the wire is integral in promoting long-life and service, the property a metallicly bonded zinc surface will provide.

SALT-SPRAY EXPOSURE TEST – ASTM B117 Salt Spray (Fog) Exposure

Worn (abraded) samples of decking used for the abrasion test were sent to an independent laboratory for salt-spray analysis. Testing was conducted using an ASTM B117 Salt Spray (Fog) Exposure test on the wire deck samples, comparing the corrosion performance between the painted, powder-coated, and zinc-coated wires. Conclusions of this testing revealed the following results:



PAINTED DECK
(Red Rust Visible)



POWDER-COATED DECK
(Red Rust Visible)



ZINC-COATED DECK
(White Rust Visible)

At the first 24 hour inspection, some visible red rust was observed on the painted and powder-coated samples on the scraped areas (worn from abrasion testing) and around the welds. White rust was observed on the J&L wires, but no red rust was visible. At each successive 24 hour inspection, there was an increase in the amount of red rust on the painted and powder-coated wires, and an increase seen in the amount of white rust on the J&L samples. At the conclusion of the testing, it was demonstrated that the J&L product outperformed the other samples by being last to reveal red rust. As expected, the protection afforded from the zinc oxide (white rust) helped to protect the base metal during this extremely aggressive test method. The ease in which the paint and powder-coated protection is damaged by normal surface abrasion caused the competitors product to deteriorate quickly.

LOAD CAPACITY RATING – ANSI MH26.2 (2007)

(Conducted Before Wear Test and After Salt-Spray Testing)

Upon completion of the salt-spray testing, all decks were load tested to compare deflection load rating capacity with their original values that had been obtained prior to testing. The values revealed a loss of strength in all three decks as follows:

- Painted decking = 12.2% loss in load capacity (deflection load rating)
- Powder-coated decking = 11.4% loss in load capacity (deflection load rating)
- Galvanized-coated decking = 1.9% loss in load capacity (deflection load rating)

Testing revealed a similar loss in load capacity for both the painted and powder-coated decks, however the loss in load capacity from the J&L galvanized deck was minimal compared with the other two decks. American workmanship and quality, combined with a superior zinc coating, has elevated the performance of the J&L product.

GLOSS TESTING – ASTM D523-14 Standard Test Method for Specular Gloss

Specular Gloss is the measure of light reflected by the surface of a material measured in gloss units. This test, conducted by an independent laboratory, was used to compare surface specular gloss of all three finishes (paint, powder-coated, and zinc-coated) in order to determine if a difference in reflectance could be noted. Measurements are standard, the typical measure samples are 20°, fixture is calibrated to the proper angle, a reading is always referenced against a angle of reflection used to 60°, and 85°. Once the test standard and set to the taken.

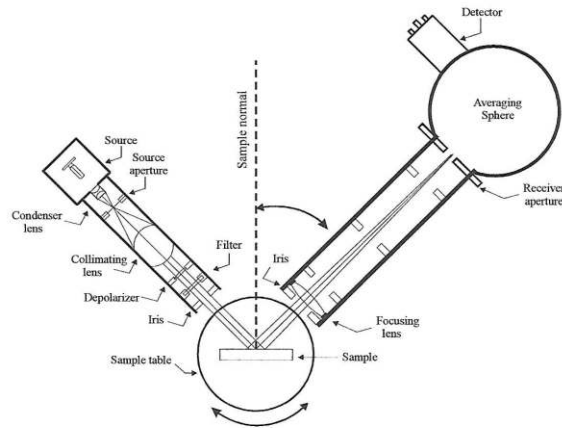

TYPICAL TEST SET UP

As expected, the galvanized (zinc-coated) wire provided by J&L reflected more light than the painted and powder-coated surfaces. Results of this testing revealed the following:

The zinc-coated (J&L) surface reflected light (average of 20°, 60°, and 85° geometries) –
54.3% better than the painted surface
74.0% better than the powder-coated surface

Gloss test results support the claim that a galvanized deck will reflect more light than the painted and powder-coated decks on the market today. This distinctive reflective property is provided by our proprietary galvanizing process. Reflective light not only helps to brighten a room, it improves the deck's look, and the overall appearance of the warehouse as well. In essence, it's a low cost incentive to improve any warehouse.

SUMMARY

Surface coatings can and will make a difference in the overall function, appearance, and life of a deck. As can be seen by recent testing, Galva-Deck™ outperformed the leading painted, and powder-coated decks available. What better way to help illuminate your warehouse, improve deck performance and overall appearance, and ensure long life from your wire decks than by using our zinc-coated galvanized wire decking.

Call our customer service representatives today and, **"Stack the Deck"** in your favor by taking advantage of our people, product, and in-house quality standards by purchasing the best wire decks available on the market today.



268 West Water Street
St. Paul, MN 55107
Phone: 866.777.8607
Fax: 651.224.6038
www.jlwire.com

